

# **Enable Networks UFB Services Agreement Service Description for Bitstream 2a**

Version 1.5 June 2026

## 1 Interpretation

- 1.1 The Bitstream 2a Service described in this Service Description will be available from the date it is launched by the LFC. The LFC will notify the Service Provider of the launch date for the Bitstream 2a Service.
- 1.2 References to clauses or sections are references to clauses or sections in this Service Description unless expressly provided otherwise. The definitions set out in the General Terms and the Operations Manual apply to this Service Description unless expressly provided otherwise.
- 1.3 References to the Operations Manual are references to the Operations Manual for the Bitstream Services.

## 2 The Bitstream 2a Service

- 2.1 The Bitstream 2a Service is a multi-class Bitstream Service suitable for accessing a wide range of internet and bespoke applications and content delivered over a shared fibre access. Bitstream 2a is part of the UFB family of Bitstream Services:

Bitstream 2a	Based on the TCF Mass Market service.
Bitstream 3	Based on the TCF Business service.
Bitstream 3a and 3b	Based on the TCF Business service, with Low Priority options.
Bitstream 4	Based on the TCF Business Premium service.
Hyperfibre 2 & 3	Based on the LFC Hyperfibre Service Description
UFB Handover Connection	Based on the TCF E-NNI specification.
Multicast	Based on the TCF Ethernet Multicast Access ( <b>EMA</b> ) service.
ATA Voice	An analogue telephone access service.

- 2.2 A diagram of the configuration for the Bitstream 2a Service is set out in Appendix A. The Bitstream 2a Service provides one or more A-EVPLs from the UNI at the End User Premises (or End User Tenancy in the case of an MDU) to the UFB Handover Connection Service located at the POI that enables a Service Provider to access and interconnect with the LFC Network.
- 2.3 The Bitstream 2a Service is an input service which a Service Provider can combine with other LFC services (or with the Service Provider's own network or wholesale services provided by other service providers) to provide fibre based telecommunications services to End Users.
- 2.4 The Bitstream 2a Service has the following key characteristics:
- 2.4.1 The Bitstream 2a Service includes one or more Access EVPL Bitstream Services delivered in conjunction with Baseband over GPON. In particular:
- (a) each Access EVPL Bitstream Service provides a single VLAN between the UNI and the E-NNI; and
  - (b) the Baseband service supports up to two instances of the ATA Voice Service.
- 2.4.2 Support for two classes of traffic, High Priority and Low Priority.

- 2.4.3 A range of Service Template package offers. Clause 3.4.6 provides an overview of the Service Templates that are initially offered, each consisting of a single Ethernet bitstream and a single ATA Voice Service package with the option to create modified or new Service Templates using 'core building blocks' and the Product Development Process.
- 2.4.4 Supports tagged or untagged traffic by the End User.
- 2.4.5 Optionally inserts Circuit ID and Remote ID information in DHCP (Version 4 and 6) and PPPoE traffic.
- 2.4.6 Complies with the Mass Market service specified in the *TCF Ethernet Access Service Description v33, 11 May 2017*.

### 3 Bitstream 2a Service and implementation activities

#### **Installation Services**

- 3.1 The Bitstream 2a Service includes a Standard Install as set out below (in each case to the extent that the relevant provisioning works are not already complete for the relevant Service Order).<sup>1</sup>

#### **Provisioning at Single Dwelling Unit End User's Premises**

- 3.1.1 A Standard Install for the Bitstream 2a Service to a Single Dwelling Unit includes:
  - (a) A Fibre Lead-in from the Fibre Access Point to an ETP at the closest convenient point on the End User Premises, as agreed with End User, where the Fibre Lead-in utilises no more than:
    - (i) 100m of approved conduit or open trench (already in place at the time of installation); or
    - (ii) a double span of aerial drop lead on existing poles from the Fibre Access Point (this will include road crossings and is available only in areas where there is overhead deployment); or
    - (iii) 30m of buried lead-in (available only in areas where there is underground deployment); and
  - (b) An extension of the Fibre Lead-in up to 10m radius from the ETP (there will not necessarily be a break in the Fibre Lead-in at the ETP) to:
    - (i) a suitable mounted SC/APC connector at a secure location inside the End User Premises; or
    - (ii) if there is an OFDF beyond the ETP, a splice or LC/APC connector on the OFDF.
- 3.1.2 The LFC will provide Non-Standard Installs for the Bitstream 2a Service to Single Dwelling Units as an Ancillary Service.

#### **Provisioning at MDU End User's Premises**

- 3.1.3 A Standard Install for the Bitstream 2a Service to an End User that is within a MDU (i.e. an End User Tenancy) includes:
  - (a) a Fibre Lead-in from the Fibre Access Point to the OFDF or equivalent at the closest convenient point within the MDU, as agreed with the MDU owner or their agent, where the Fibre Lead-in utilises no more than:
    - (i) 100m of approved conduit or open trench (already in place at the time of installation); or

---

<sup>1</sup> Standard Install parameters may differ between LFCs.

- (ii) a double span of aerial drop lead on existing poles from the Fibre Access Point (this will include road crossings and is available only in areas where there is overhead deployment); or
  - (iii) 30m of buried lead-in (available only in areas where there is underground deployment); and
- (b) where the fibre cabling in a MDU to the End User Tenancy is not already in place at the time of installation of the Bitstream 2a Service, fibre cabling within the MDU to extend the Fibre-Lead-in from the OFDF or equivalent to the End-User Tenancy; and
- (c) either:
- (i) a further extension of the Fibre Lead-in up to 10m radius from the ETP at the End User Tenancy (there will not necessarily be a break in the Fibre Lead-in at the ETP) to:
    - (A) a suitable mounted SC/APC connector at a secure location; or
    - (B) if there is an OFDF beyond the ETP, a splice or LC/APC connector on the OFDF,
 within the End User Tenancy; or
  - (ii) if there is not an ETP at the End User Tenancy as contemplated by clause 3.1.3(c)(i), a further extension of the Fibre Lead-in up to 10m radius from the boundary of the End User Tenancy to:
    - (A) a suitable mounted SC/APC connector at a secure location; or
    - (B) if there is an OFDF beyond the boundary, a splice or LC/APC connector on the OFDF,
 within the End User Tenancy.
- 3.1.4 The extended LFC Network fibre within the MDU is the Fibre Lead-in to an End User Tenancy, whether currently in use or not. The Fibre Lead-in is only available for use by the LFC.
- 3.1.5 The LFC will provide Non-Standard Installs for the Fibre Lead-in to End User Tenancies within MDUs as an Ancillary Service.

**Single Dwelling Unit Termination Point**

- 3.1.6 For a Single Dwelling Unit, the termination point of the Layer 1 component of the Bitstream 2a Service for the purposes of the Connection at the End User's Premises, and the network demarcation point between the LFC Network and the Premises wiring is, as applicable, either:
- (a) the SC/APC connector on the end of the Fibre Lead-in from the ETP (which is the connector); or
  - (b) if there is an OFDF beyond the ETP, a splice or LC/APC connector on the OFDF,
- provided that any ONT installed by the LFC as part of the Bitstream 2a Service will also be part of the LFC Network.
- 3.1.7 The termination point of the Layer 2 component of the Bitstream 2a Service is the 100/1000Base-T UNI on the ONT.

### **MDU Termination Point**

- 3.1.8 For MDUs, the termination point of the Layer 1 component of the Bitstream 2a Service for the purposes of the Connection at the End User's Tenancy, and the network demarcation point is as applicable, either:
- (a) the SC/APC connector on the end of the Fibre Lead-in (which is the jack); or
  - (b) if there is an OFDF beyond the ETP or End User Tenancy boundary, a splice or LC/APC connector on the OFDF,
- within the End User Tenancy, provided that any ONT installed by the LFC as part of the Bitstream 2a Service will also be part of the LFC Network.
- 3.1.9 The termination point of the Layer 2 component of the Bitstream 2a Service is the 100/1000Base-T UNI on the ONT.

### **Alternative Termination Points**

- 3.1.10 The LFC and the Service Provider may agree on a different termination point as part of a Non-Standard Install. A Non Standard Install for a Bitstream 2a Service within a Multi Dwelling Unit will not include termination in a building common area or other facility made available by the owner to service the Multi Dwelling Unit, where a Fibre Lead-in has not been extended from the OFDF to the inside of an End User Tenancy.

### **Installation of ONT**

- 3.1.11 A Standard Install for the Bitstream 2a Service includes installation of an ONT including:
- (a) supply and fixing of the ONT to the structure of the End User Premises (in the case of a Single Dwelling Unit) or an End User Tenancy (in the case of an MDU);
  - (b) supply and connection of fibre pigtail up to 1m long between the Fibre Lead-in termination point and the ONT if required; and
  - (c) testing from the UNI port of the ONT to ensure the Bitstream 2a Service is within the technical specification set out in Appendix B.
- 3.1.12 The Service Provider must ensure the End User provides a suitably located mains power outlet for the ONT power supply which is not provided as part of a Standard Installation.
- 3.1.13 The LFC will not provide space and power at any End User Premise for the ONT. These are the responsibility of the End User. The location of the ONT must be a suitable environment for electronic equipment being generally a dry, clean indoor area with adequate ventilation.

### **Testing**

- 3.2 The LFC will test the Fibre Lead-in from the termination point at the End User's Premises referred to in clause 3.1.6, 3.1.7 or 3.1.10 to the Central Office where the access node is located to ensure the fibre is within the technical specification for fibre set out in Appendix B.

### **Additional Services**

- 3.3 If the Service Provider requires additional services such as:
- 3.3.1 A Non-Standard Install which includes (where required):
- (a) an extension of the Fibre Lead-in over the maximum distances specified in clauses 3.1.1 (in relation to Single Dwelling Units) or 3.1.3 (in relation to End User Tenancies within MDU's); or
  - (b) installation of Fibre-Lead-in diversity at an End User's Premises (from the FAP to the ETP or OFDF as applicable);
- 3.3.2 Provision of diversity to End User's Premises (when the second or subsequent instance

of the Bitstream 2a Service is purchased);

3.3.3 Premises wiring services; or

3.3.4 Installation and testing of Service Provider equipment and services,

then the LFC may be able to provide the services in clauses 3.3.2 to 3.3.4 on request, subject to terms to be agreed between the LFC and the Service Provider. The services in clause 3.3.1 and 3.3.2 are available on terms as set out in this Agreement.

### **Core Bitstream 2a Service**

3.4 The core Bitstream Services provided as part of the Bitstream 2a Service are as follows:

3.4.1 One or more A-EVPLs, each consisting of:

- (a) a single 802.1q VLAN on a designated UNI on the ONT at the End User Premises;
- (b) a single 802.1ad or QinQ VLAN (Service VLAN ID/Customer VLAN ID) on the E-NNI at the POI; and
- (c) a QOS bandwidth profile that describes how traffic is carried between these points.

3.4.2 Ten per cent (10%) bandwidth overhead for Low Priority EIR traffic to compensate for higher protocol encapsulation overheads on service templates less than 1000/500. This bandwidth overhead does not guarantee End Users will experience the headline speed as their experience is dependent on a number of external factors including, but not limited to, End User applications, CPE and local network, the Service Provider network and location of the content they are accessing.

3.4.3 Untagged traffic sent from the End User is tagged and marked as Low Priority.

3.4.4 Tagged Traffic is treated as follows:

- (a) Traffic tagged with PCP = 5 will be treated as High Priority.
- (b) Traffic tagged with PCP = 0 will be treated as Low Priority.
- (c) Traffic tagged ingressing the E-NNI with a SVLAN PCP = 1, 2, 3, 4, 6 or 7 will be remarked as PCP 0 and treated as Low Priority.
- (d) Traffic tagged ingressing the UNI with PCP = 1, 2, 3, 4, 6 or 7 will be encapsulated with a SVLAN having a PCP of 0 and treated as Low Priority.
- (e) Traffic will be treated as follows:

Type	Ingress	Transport
Low Priority	CIR > 0. EIR > 0 EIR + CIR Policed at Ingress	CIR + EIR dropped according to its SVLAN PCP value under congestion conditions
High Priority	CIR policed at ingress EIR = 0.	Prioritised

3.4.5 The Bitstream 2a Service includes the options, exercised by Service Request, to:

- (a) set the UNI as an untagged interface. If this feature is requested then the network will remove all 802.1q tags from downstream traffic and present it as 802.3 Ethernet frames from the UNI; and
- (b) enable Circuit ID and Remote ID per A-EVPL, as specified in Broadband Forum TR-101/TR-156, per tail. If this feature is requested TR-101 information will be embedded in DHCP or PPPoE traffic. The Circuit ID format may differ from the examples provided in TR-101/TR-156.

3.4.6 Initial Service Templates are available consisting of a Baseband Service with one instance of the ATA Voice Service and one Access EVPL Bitstream Service as follows:

Template	ATA1 ports	Headline <sup>2</sup>				Low Priority PIR <sup>3</sup>		Low Priority Downstream				Low Priority Upstream				High Priority Downstream				High Priority Upstream			
		Low Priority (Mbps)		High Priority (Mbps)		PIR <sup>3</sup> (Mbps)		EIR <sup>6</sup>	EBS <sup>7</sup>	CIR	CBS <sup>7</sup>	EIR <sup>6</sup>	EBS <sup>7</sup>	CIR	CBS <sup>7</sup>	EIR <sup>6</sup>	EBS <sup>7</sup>	CIR	CBS <sup>7</sup>	EIR <sup>6</sup>	EBS <sup>7</sup>	CIR	CBS <sup>7</sup>
		Down	Up	Down	Up	Down	Up	Mbps	kB	Mbps	kB	Mbps	kB	Mbps	kB	Mbps	kB	Mbps	kB	Mbps	kB	Mbps	kB
Bitstream 2a 0-0-2.5-2.5	1	0.064	0.064	2.5	2.5	0.064	0.064	0.064	8	0.0	0	0.064	8	0.0	0	0	0	2.5	32	0	0	2.5	32
Bitstream 2a 100-20-2.5-2.5 <sup>4</sup> (Fibre Starter)	1	100	20	2.5	2.5	112.5	24.5	110	180	2.5	32	22	180	2.5	32	0	0	2.5	32	0	0	2.5	32
Bitstream 2a 100-20-2.5-2.5 <sup>4</sup>	1	100	20	2.5	2.5	112.5	24.5	110	180	2.5	32	22	180	2.5	32	0	0	2.5	32	0	0	2.5	32
Bitstream 2a 50-50-5-5	1	50	50	5	5	57.5	57.5	55	130	2.5	32	55	90	2.5	32	0	0	5	32	0	0	5	32
Bitstream 2a 500-100-2.5-2.5 <sup>4</sup>	1	500	100	2.5	2.5	552.5	112.5	550	250	2.5	32	110	180	2.5	32	0	0	2.5	32	0	0	0	0
Bitstream 2a 300-300-5-5	1	300	300	5	5	332.5	332.5	330	180	2.5	32	330	180	2.5	32	0	0	5	32	0	0	5	32
Bitstream 2a 1000-500-2.5-2.5 <sup>4</sup>	1	Max <sup>5</sup>	500	2.5	2.5	Max <sup>5</sup>	542.5	Max <sup>5</sup>	250	2.5	32	540	180	2.5	32	0	0	2.5	32	0	0	2.5	32
Bitstream 2a 1000-500-5-5	1	Max <sup>5</sup>	500	5	5	Max <sup>5</sup>	542.5	Max <sup>5</sup>	250	2.5	32	540	180	2.5	32	0	0	5	32	0	0	5	32

[1] The ATA service is as described in the ATA Voice Service Description except that the High Priority frames are tagged with PCP 5.

[2] The headline rate is the Layer 2 bandwidth prior to the addition of the overhead (10% LP EIR).

[3] Low Priority 'Peak Information Rate' (PIR) is the headline rate plus the bandwidth overhead described in section 3.4.2 plus the Low Priority CIR.  
Low Priority PIR = Low Priority EIR + Low Priority CIR.

[4] Available for Residential Connections only

[5] Low priority Downstream is set to 1000 Mbps. The maximum throughput of the UNI is 1000 Mbps including Ethernet preamble, frame delimiters and inter-frame gaps. Thus the maximum throughput will be less than the UNI speed and vary according to frame size.

[6] These values are the layer 2 bandwidths and include the additional overhead compensation described in section 3.4.2.

[7] Burst sizes are minimum values only

[NB] Further Service Templates may be developed in future to facilitate the availability of other bandwidth profiles built from separate building blocks. However building blocks are not intended to enable the Bitstream 2a upstream CIR bandwidth to extend beyond a total of 50 Mbps (High Priority plus Low Priority), or downstream CIR bandwidth to extend beyond a total of 100Mbps (High Priority plus Low Priority).

3.4.7 The Bitstream 2a Service has similar characteristics to the other services within the UFB family of Bitstream Services as identified below:

Attribute	Bitstream 2a	Bitstream 3	Bitstream 3a	Hyperfibre 2	Hyperfibre 3	Bitstream 4
Bitstream	A-EVPL	A-EPL	A-EPL	A-EVPL	A-EPL	A-EPL
High Priority	Yes	Yes	Yes	Yes	Yes	Yes
Low Priority	Yes	No	Yes	Yes	Yes	No
Service Bandwidths <sup>2</sup>	From 50/20 Mbps up to 1000/500 Mbps	From 2.5Mbps up and downstream to 100/100 Mbps	100/100 Mbps with High Priority from 2.5Mbps	2 Gbps 4 Gbps 8 Gbps	2 Gbps 4 Gbps 8 Gbps	100 Mbps 200 Mbps 500Mbps 1 Gbps 4 Gbps 10 Gbps
MTU	2000 Bytes	2000 Bytes	2000 Bytes	2000 Bytes	2000 Bytes	9100 Bytes
MAC addresses	16	64	64	16	64	128
Number of available UNIs <sup>3</sup>	4 standard	4 standard	4 standard	1x 10G RJ45 1x 1G RJ45	1x 10G RJ45 1x 1G RJ45	1 (with a second UNI available on request for NID only)
L2CP support	No	No	No	No	No	Limited
Diversity	On request with limited availability	On request with limited availability	On request with limited availability	On request with limited availability	On request with limited availability	Available to Priority Users in selected areas

#### **UNI - NNI characteristics**

- 3.4.8 All Bitstream 2a Services on a UNI must belong to the same Service Provider and must connect to an E-NNI belonging to that Service Provider. However, each Bitstream 2a Service can connect to a different E-NNI at the same or different geographic location within a Coverage Area.
- 3.4.9 The sum of High and Low Priority traffic profiles of all services delivered at a UFB Handover Connection Service can exceed the UFB Handover Connection Service line rate. If there is insufficient line rate to deliver the traffic then frames will be randomly discarded, based on their Class of Service precedence, and Service Levels for that Class of Service do not apply. It is therefore the Service Provider's responsibility to shape and queue traffic appropriately.

#### **New Service Template Options**

3.5 A Service Provider may request that the LFC creates additional Service Templates as follows:

3.5.1 Additional Bitstream 2a Service Templates can be created using combinations of one more of the following set of standard building blocks:

- (a) Point-to-Point single VLAN Ethernet Bitstream Service (A-EVPL) service

<sup>2</sup> Bandwidth options for each Bitstream Service are detailed in each Bitstream Service Description and further options can be developed using the Product Development Process.

<sup>3</sup> Number of available UNIs assumes Bitstream 2a,3,3a and 3b are delivered on a GPON ONT and Hyperfibre 2 and 3 are delivered on an XGSPON ONT.

using High Priority and Low Priority combinations as set out in this Service Description and in clause 3.5.2 below. Multiple A-EVPLs can be configured on the same or on different UNIs;

- (b) Multicast VLAN Ethernet Bitstream service (EMA) using High Priority only;
- (c) ATA Voice port;
- (d) UNI (100/1000 Base-T) port;
- (e) WiFi; and
- (f) Other services or attributes requested by the Service Provider and agreed by the LFC.

3.5.2 Ethernet Bitstream Services consisting of High Priority and Low Priority traffic combinations can be created using the following standard building blocks:

- (a) High Priority CIR in increments of 2.5 Mbps upstream and/or downstream;
- (b) Low Priority EIR in increments of 10 Mbps upstream and/or downstream.

3.6 Service Templates can be added incrementally to an existing service offer, or supplied as a stand-alone package.

3.6.1 Stand alone packages must include Baseband. Stand alone packages mean that the End User connection does not need to consume any other Service Templates in order for services to be provided.

3.6.2 Incremental packages can be added as an additional service to an End User who is already consuming one or more Service Templates.

3.6.3 Baseband is a required service for all End User connections. If the Service Template that includes Baseband is removed from an End User connection and an incremental Service Template remains, then Baseband will be added to the incremental Service Template for that End User.

3.7 Requests for additional Service Templates will be implemented and delivered through the Product Development Process. The Product Development Process includes determination of pricing, development, testing and implementation.

3.8 The LFC will comply with the Service Provider's request under clause 3.5 in a timely manner. In the event that demand for new Service Templates exceeds the LFC's capacity to deliver the new Service Templates then the LFC may prioritise the Service Template requests in accordance with the Operations Manual.

### **Operations, Administration and Maintenance**

3.9 The Bitstream 2a Service will support (at a future date) Service Provider remote access to the ONT via a service management gateway for appropriate management. A Service Provider may request particular management attributes via the Product Development Process.

3.10 The Bitstream 2a Service will support Ethernet Service Operations and Maintenance (**OAM**) for service integrity testing, fault diagnostics and performance measurement using ITU Y.1731. OAM capability will be phased in as the functionality is developed and deployed in scale and may be updated or amended by the LFC from time to time.

### **Service Requirements**

3.11 To use the Bitstream 2 a Service the Service Provider must have the capability to access and interconnect with it, by one of the following:

- 3.11.1 Co-locating Service Provider equipment at the POI using the UFB Handover Connection Service and Central Office and POI Co-location Service;

- 3.11.2 Connecting to third party co-location space at the POI using the UFB Handover Connection Service, and with the third party taking the Central Office and POI Co-location Service;
- 3.11.3 Connecting to a backhaul service at the POI; or
- 3.11.4 By using the Direct Fibre Access Service to connect to Service Provider equipment at a remote location within the Central Office area.
- 3.11.5 Co-locating Service Provider equipment at the POI using the UFB Handover Connection Service and a third party co-location service.

**Additional Service Characteristics**

- 3.12 The technical specification of the Bitstream 2a Service is set out in Appendix B.
- 3.13 The LFC will provide certain support and other assistance as part of the Bitstream 2a Service including:
  - 3.13.1 An automated facility for Service Requests;
  - 3.13.2 An automated facility for fault notifications; and
  - 3.13.3 A tool to assist the Service Provider in determining the location and availability of the Bitstream 2a Service (pre-qualification),
 each as more particularly set out in the Operations Manual.
- 3.14 The Bitstream 2a Service specifically excludes:
  - 3.14.1 The UFB Handover Connection Service;
  - 3.14.2 Provision or maintenance of any cabling or connection or active device:
    - (a) beyond the service demarcation points described in clause 4.1 and clause 5.1;
    - (b) between the jack terminating the LFC provided Fibre Lead-in and the ONT, where that cabling or connection is not provided by the LFC and the LFC has not agreed to take responsibility for that cabling or connection;
  - 3.14.3 Configuration, monitoring, operation, on-going support or maintenance of Service Providers' or End Users' applications, equipment or networks; and
  - 3.14.4 Supply of AC mains & UPS power, accommodation space, heating, ventilating, and air conditioning and facilities at the POI or End User Premises.

**4 Service Demarcation Point at End User Premises**

- 4.1 The service demarcation point at the End User's Premises is the 100/1000Base-T UNI on the ONT.
- 4.2 The Bitstream 2a Service excludes the End User Premises wiring. If a fault reported by the Service Provider is found to be caused by the End User Premises equipment (CPE) or the wiring at the End User's Premises beyond the service demarcation point, then the Service Provider may be charged the no fault found fee in the Price List. Note the wiring should comply with the industry standard Premises wiring requirements which are available at [www.tcf.org.nz](http://www.tcf.org.nz).

**5 Service Demarcation Point at POI**

- 5.1 The Bitstream 2a Service is delivered as a single VLAN (the logical service demarcation point) on the UFB Handover Connection located at the POI.
- 5.2 The physical service demarcation point is the MOFDF in the POI, which is part of the UFB Handover Connection Service.

5.3 The UFB Handover Connection Service is a separate service and is a prerequisite to the supply of the Bitstream 2a Service, i.e. Service Provider's must first purchase and then continue to maintain a UFB Handover Connection Service at all times while taking the Bitstream 2a Service.

## **6 LFC and Service Provider Responsibilities**

6.1 Other LFC and Service Provider responsibilities are detailed in the General Terms and the Operations Manual.

## **7 Fibre Diversity**

7.1 The Bitstream 2a Service provides a single fibre between the Central Office and the local cabinet.

7.2 The Bitstream 2a Service does not support network route diversity. Network route diversity can be achieved by utilising a diverse Bitstream 4 Service or diverse Direct Fibre Access Service in conjunction with a Bitstream 2a Service.

7.3 The Bitstream 2a Service supports on-premises access route diversity (from the FAP to the ETP) comprising of a separate fibre from the cabinet to the End User Premises.

## **8 Bitstream 2a Service Levels**

8.1 Service Levels for the Bitstream 2a Service are set out in the Service Level Terms for the Bitstream Services.

## Appendix A - Diagram

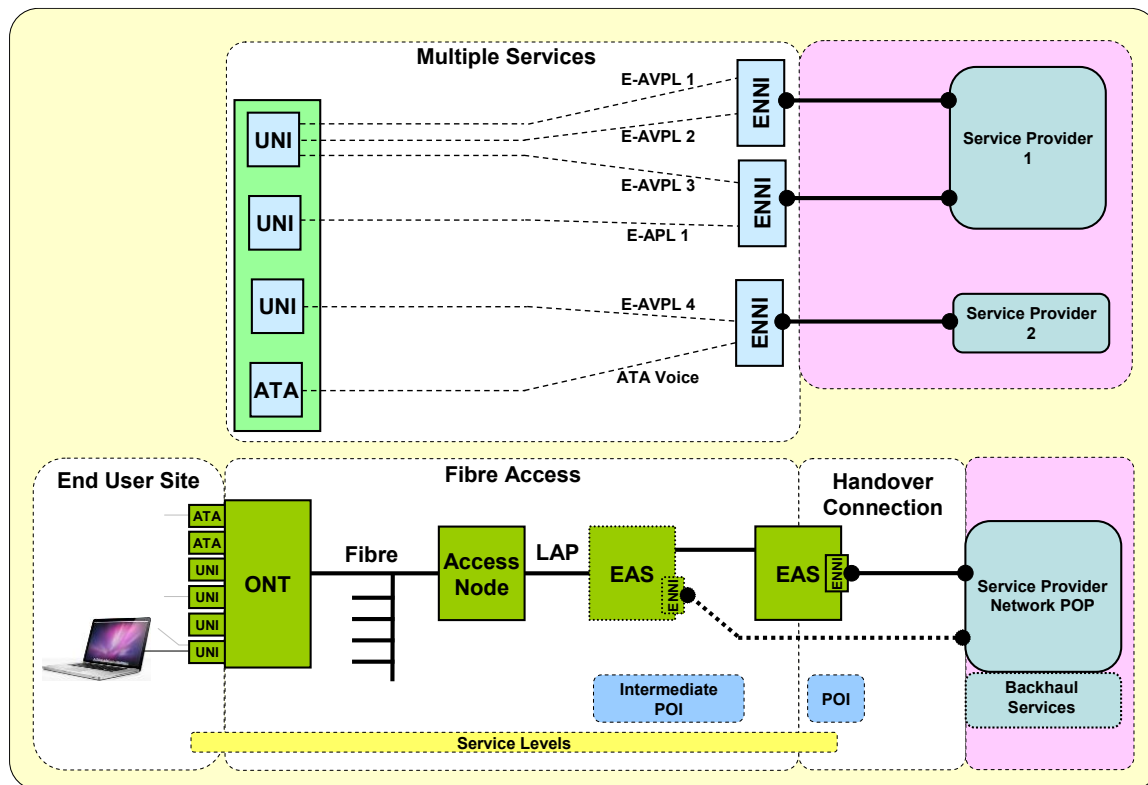

This is a generic diagram showing the standard configuration and service demarcation points. It is not intended to represent every situation or detailed physical architecture. The following points should be noted:

- The Bitstream 2a Service and pricing applies from the UNI to the E-NNI at the POI, i.e. there is no incremental charge from the Intermediate POI to the POI.
- Some Bitstream Services will have a single tier of aggregation, i.e. there is no Intermediate POI.
- Where there are multiple tiers of aggregation, the Service Provider can pick the service up at an Intermediate POI. This intermediate POI will service a limited Coverage Area.
- Service Levels (availability, network performance) only apply to UNI to the E-NNI at the POI.
- Access node and aggregation interconnection may use redundant links to meet Service Level requirements.

The Bitstream Services support simultaneous delivery of multiple Service Templates from the same or multiple service providers as follows:

- Multiple A-EVPLs can be delivered to the same UNI.
- An A-EPL service requires a dedicated UNI.
- An ATA Voice Service can be considered an A-EVPL with an ATA Voice port at the End User interface. The class and bandwidth characteristics of this A-EVPL are optimised for voice.
- All services delivered to a UNI must belong to the same Service Provider but can be mapped to the same or different E-NNIs.
- The initial Bitstream 2a Service Templates contain a single A-EVPL and one ATA Voice Service.

## Appendix B - Technical Specification

Technical Specification	
Ethernet	Ethernet II or 802.3 untagged interface; or 802.1q tagged interface with: <ul style="list-style-type: none"> <li>• VLAN id = as agreed with Service Provider;</li> <li>• 802.1p = 0, 1, 2, 3, 4, 6, 7 (Low Priority); or</li> <li>• 802.1p = 5 (High Priority).</li> </ul>
UNI	ONT supports: <ul style="list-style-type: none"> <li>• 4 x UNI; and</li> <li>• 2 x ATA Voice ports.</li> <li>• Optional additional ports:               <ul style="list-style-type: none"> <li>○ RF Overlay port; and</li> <li>○ WiFi.</li> </ul> </li> </ul> Per UNI: <ul style="list-style-type: none"> <li>• 100/1000Base-T.</li> </ul>
UFB Handover Connection (E-NNI)	Ethernet: <ul style="list-style-type: none"> <li>• 802.1ad VLAN (SVID, CVID); or</li> <li>• Double tagged QnQ.</li> </ul>
VLAN	Point-to-Point (E-AVPL). MTU 2000 Bytes. Unicast Frame Delivery = passed within service CIR/EIR. Multicast Frame Delivery = passed within service CIR/EIR. Broadcast Frame Delivery = passed within service CIR/EIR. Layer 2 Control Protocols Processing = initially none (but may be amended by LFC from time to time).
Fibre	External fibre must comply with ITU-T specification G.652D. Internal building fibres may comply with ITU-T G.657A but must meet appropriate fire regulations. Fibre terminations must be SC/APC type connectors (complying with the IEC 61754-4 standard) or alternatively LC/APC type connectors (complying with the IEC 61754-20 standard) as appropriate. Laser types and path characteristics expected to be designed to a minimum standard which are contained in the documents IEEE 802.3 Section 5 standard OR distance specifications as per the ITU-T G.984 (GPON) standard as appropriate. Testing for power loss will be at either 1310 or 1550 nm. 1625 nm reserved for non disruptive testing.