

# **Enable Networks UFB Services Agreement Service Description for Hyperfibre Services**

**Version 2.0 March 2026**

## 1 Interpretation

- 1.1 References to clauses or sections are references to clauses or sections in this Service Description unless expressly provided otherwise. The definitions set out in the General Terms and the Operations Manual apply to this Service Description unless expressly provided otherwise.
- 1.2 References to the Operations Manual are references to the Operations Manual for the Bitstream Services.

## 2 The Hyperfibre Service

- 2.1 The Hyperfibre Service is a high-speed multi-class bitstream service suitable for accessing a wide range of internet and bespoke applications and content delivered over a point to multipoint fibre access.
- 2.2 Hyperfibre comes in two service variants:
  - 2.2.1 Hyperfibre A-EVPL Service: A Bitstream 2a-like Access EVPL bitstream service that connects a UNI or Open Access Gateway function in the End User premises to a single S-VLAN/C-VLAN on a UFB Handover Connection service located at the POI,
  - 2.2.2 Hyperfibre A-EPL Service: Bitstream 3a-like Access-EPL bitstream service that connects a UNI in the End User premises to a single S-VLAN on a UFB Handover Connection service located at the POI,  
  
where the UFB Handover Connection enables a Service Provider to access and interconnect with the LFC Network.
- 2.3 A diagram of the configuration for the Hyperfibre Service is set out in Appendix A.
- 2.4 The Hyperfibre Service is an input service which a Service Provider can combine with other LFC services (or with the Service Provider's own network or wholesale services provided by other service providers) to provide fibre-based telecommunications services to End Users.
- 2.5 The Hyperfibre 2 A-EPVL Service has the following key characteristics:
  - 2.5.1 One or more Ethernet A-EVPL Bitstream Services delivered in conjunction with Baseband. In particular:
    - (a) each Ethernet A-EVPL Bitstream Service provides a single VLAN between the UNI and the E-NNI; and
    - (b) the Baseband service supports up to two instances of the ATA Voice Service, which can be added as an additional service.
  - 2.5.2 Support for two classes of traffic, High Priority and Low Priority.
  - 2.5.3 A range of Service Template package offers. Clause 3.7 provides an overview of the Service Templates that are initially offered consisting of a single Access EVPL Bitstream with a range of bandwidth options.
  - 2.5.4 Supports tagged or untagged traffic by the End User at the UNI.
  - 2.5.5 Optionally inserts Circuit ID and Remote ID information in DHCP (Version 4 and 6) and PPPoE traffic.
  - 2.5.6 Complies with the Mass Market service specified in the TCF Ethernet Access Service Description v33, 11 May 2017.
- 2.6 The Hyperfibre 3 A-EPL Service variant has the following key characteristics:
  - 2.6.1 It includes an Ethernet Bitstream Service that allows up to 4050 VLANs to be passed

transparently from the End User Premises to the Service Provider, delivered over PON (shared) fibre.

- 2.6.2 Support for two classes of traffic, High Priority and Low Priority.
- 2.6.3 Supports tagged or untagged traffic by the End User at the UNI.
- 2.6.4 Complies with the Business service specified in the Telecommunications Carriers Forum's Ethernet Access Service Description v33, 11 May 2017 for a Business service with the following clarifications:
  - (a) Clause 10.1.4 Multiclass: Only the option supporting a high and low class is supported. The single class service is not supported.
  - (b) Clause 10.1.10 Colour: The Egress Colour Marking is implemented as defined for the "OFF" option, that is, the DEI is always set to 0.
  - (c) Clause 10.5.3 Other Attributes: The maximum number of Hyperfibre 3 UNIs on a single ONT is limited to 1.

### **3 Hyperfibre Service and Implementation activities**

#### ***Installation Services***

- 3.1 The Hyperfibre Service includes a Standard Install, where applicable, as set out below (in each case to the extent that the relevant provisioning works are not already complete for the relevant Service Order).
- 3.2 The Hyperfibre Service includes a standard migration from GPON to XGS-PON, where applicable, which includes:
  - 3.2.1 Removal of the current GPON ONT and fibre pigtail;
  - 3.2.2 Supply of the Hyperfibre XGS ONT and the supply and connection of a fibre pigtail between the ITP and the Hyperfibre XGS ONT;
  - 3.2.3 Supply of XGS-PON port with its associated combiner (if required) in the LFC network;
  - 3.2.4 Repatching within the roadside fibre flexibility point; and
  - 3.2.5 Reconfiguration, if applicable, of the Central Office fibre pigtail to enable connection to the XGS-PON port.

#### **Provisioning at SDU End User's Premises:**

- 3.2.6 A Fibre Lead-in from the Fibre Access Point to an ETP at the closest convenient point on the End User Premises, as agreed with End User, where the Fibre Lead-in utilises no more than:
  - (i) 100m of approved conduit or open trench (already in place at the time of installation); or
  - (ii) a double span of aerial drop lead on existing poles from the Fibre Access Point (this will include road crossings and is available only in areas where there is overhead deployment); or
  - (iii) 30m of buried lead-in (available only in areas where there is underground deployment); andan extension of the Fibre Lead-in up to 10m radius from the ETP (there will not necessarily be a break in the Fibre Lead-in at the ETP) to:
  - (iv) a suitable mounted SC/UPC connector at a secure location inside the End User Premises; or
  - (v) if there is an OFDF beyond the ETP, a splice or LCA connector on the OFDF.
- 3.2.7 The LFC will provide Non-Standard Installs for the Hyperfibre Service to Single Dwelling Units as an Ancillary Service.

### **Provisioning at MDU End User's Premises**

- 3.2.8 A Standard Install for the Hyperfibre Service to an End User that is within a MDU (i.e. an End User Tenancy) includes:
- (a) a Fibre Lead-in from the Fibre Access Point to the OFDF or equivalent at the closest convenient point within the MDU, as agreed with the MDU owner or their agent, where the Fibre Lead-in utilises no more than:
    - (i) 100m of approved conduit or open trench (already in place at the time of installation); or
    - (ii) a double span of aerial drop lead on existing poles from the Fibre Access Point (this will include road crossings and is available only in areas where there is overhead deployment); or
    - (iii) 30m of buried lead-in (available only in areas where there is underground deployment); and
  - (b) where the fibre cabling in a MDU to the End User Tenancy is not already in place at the time of installation of the Hyperfibre Service, fibre cabling within the MDU to extend the Fibre-Lead-in from the OFDF or equivalent to the End-User Tenancy; and
  - (c) either
    - (i) a further extension of the Fibre Lead-in up to a 10m radius from the ETP at the End User Tenancy (there will not necessarily be a break in the Fibre Lead-in at the ETP) to:
      - (ii) a suitable mounted SC/UPC connector at a secure location; or
      - (iii) if there is an OFDF beyond the ETP, a splice or LCA connector on the OFDF,within the End User Tenancy; or
    - (iv) if there is not an ETP at the End User Tenancy as contemplated by clause 3.2.8(c)(i), a further extension of the Fibre Lead-in up to 10m radius from the boundary of the End User Tenancy to:
      - (v) a suitable mounted SC/UPC connector at a secure location; or
      - (vi) if there is an OFDF beyond the boundary, a splice or LCA connector on the OFDF,within the End User Tenancy.
- 3.2.9 The extended LFC Network fibre within the MDU is the Fibre Lead-in to an End User Tenancy, whether currently in use or not. The Fibre Lead-in is only available for use by the LFC.
- 3.2.10 The LFC will provide Non-Standard Installs for the Fibre Lead-in to End User Tenancies within MDUs as an Ancillary Service.

### **Single Dwelling Unit Termination Point**

- 3.2.11 For a Single Dwelling Unit, the termination point of the Layer 1 component of the Hyperfibre Service for the purposes of the Connection at the End User Premises, and the network demarcation point between the LFC Network and the Premises wiring is, as applicable, either:
- (a) the SC/APC connector on the end of the Fibre Lead-in from the ETP (which is the connector); or
  - (b) if there is an OFDF beyond the ETP, a splice or LCA connector on the OFDF,
- provided that any ONT installed by the LFC as part of the Hyperfibre Service will also be part of the LFC Network.
- 3.2.12 The termination point of the Layer 2 component of the Hyperfibre Service is the 10000Base-T (10 Gbps) UNI interface on the ONT.

### ***MDU Termination Point***

- 3.2.13 For MDUs, the termination point of the Layer 1 component of the Hyperfibre Service for the purposes of the Connection at the End User's Tenancy, and the network demarcation point is as applicable, either:
- (a) the SC/APC connector on the end of the Fibre Lead-in (which is the jack); or
  - (b) if there is an OFDF beyond the ETP or End User Tenancy boundary, a splice or LCA connector on the OFDF,
- within the End User Tenancy, provided that any ONT installed by the LFC as part of the Hyperfibre Service (or already installed at the End User Premises) will also be part of the LFC Network.
- 3.2.14 The termination point of the Layer 2 component of the Hyperfibre Service is the 10000Base-T (10 Gbps) UNI interface on the ONT.

### ***Alternative Termination Points***

- 3.2.15 The LFC and the Service Provider may agree on a different termination point as part of a Non-Standard Install. A Non-Standard Install for a Hyperfibre Service within a Multi Dwelling Unit will not include termination in a building common area or other facility made available by the owner to service the Multi Dwelling Unit, where a Fibre Lead-in has not been extended from the OFDF to the inside of an End User Tenancy

### ***Installation of ONT***

- 3.2.16 An install for the Hyperfibre Service will include the installation of a new XGS-PON ONT including:
- (a) supply and fixing of the ONT to the structure of the End User Premises (in the case of a Single Dwelling Unit or an End User Tenancy (in the case of an MDU);
  - (b) supply and connection of fibre pigtail up to 1m long between the Fibre Lead-in termination point and the ONT if required; and
  - (c) testing from the UNI port of the ONT to ensure the Hyperfibre Service is within the technical specification set out in Appendix B.
- 3.2.17 The Service Provider must ensure the End User provides a suitably located mains power outlet for the ONT power supply.
- 3.2.18 The LFC will not provide space and power at any End User Premises for the ONT. These are the responsibility of the End User. The location of the ONT must be a suitable environment for electronic equipment being generally a dry, clean indoor area with adequate ventilation.

### ***Testing***

- 3.3 The LFC will test the Fibre Lead-in from the termination point at the End User Premises to the Central Office where the access node is located to ensure the fibre is within the technical specification for fibre set out in Appendix B.

### ***Additional Services***

- 3.4 If the Service Provider requires additional services such as:
- 3.4.1 a Non-Standard Install which includes (where required):
    - (a) an extension of the Fibre Lead-in over the maximum distances specified in clauses 3.2.7 (in relation to Single Dwelling Units) or 3.2.10 (in relation to End User Tenancies within MDUs);
    - (b) installation utilising specialised termination equipment; or
    - (c) installation of Fibre-Lead-in diversity at an End User's Premises (from the FAP to the ETP or OFDF as applicable).
  - 3.4.2 provision of diversity to End User's Premises (when the second or subsequent instance of

- 3.4.3 the GPON/Hyperfibre Service is purchased).
- 3.4.4 Premises wiring services; or
- 3.4.5 Installation and testing of Service Provider equipment and services,

then the LFC may be able to provide the services on request, subject to terms to be agreed between the LFC and the Service Provider (including any applicable Charges).

**Core Hyperfibre Service**

3.5 The core Bitstream Services provided as part of the A-EVPL Hyperfibre 2 Service are as follows:

- 3.5.1 One or more A-EVPLs, each consisting of:
  - (a) a single 802.1q VLAN on a designated UNI on the ONT at the End User Premises;
  - (b) a single 802.1ad or QinQ VLAN (Service VLAN ID/Customer VLAN ID) on the E-NNI at the POI; and
  - (c) a QOS bandwidth profile that describes how traffic is carried between these points.
- 3.5.2 Additional bandwidth overhead for Low Priority EIR traffic to compensate for higher protocol encapsulation overheads. This bandwidth overhead does not guarantee End Users will experience the headline speed as their experience is dependent on a number of external factors including, but not limited to, End User applications and local network, the Service Provider network, and location of the content they are accessing.
- 3.5.3 Untagged traffic sent from the End User is tagged and marked as Low Priority.
- 3.5.4 Tagged Traffic is treated as follows:
  - (a) Traffic tagged with PCP = 5 will be treated as High Priority.
  - (b) Traffic tagged with PCP = 0 will be treated as Low Priority.
  - (c) Traffic tagged ingressing the E-NNI with a SVLAN PCP = 1, 2, 3, 4, 6 or 7 will be remarked as PCP 0 and treated as Low Priority.
  - (d) Traffic tagged ingressing the UNI with PCP = 1, 2, 3, 4, 6 or 7 will be encapsulated with a SVLAN having a PCP of 0 and treated as Low Priority.
  - (e) Traffic will be treated as follows:

Type	Ingress	Transport
Low Priority	CIR > 0 EIR > 0 EIR + CIR policed at ingress <b>For the Hyperfibre Service:</b> CIR ≥ 10 Mbps EIR ≥ 0 EIR + CIR policed at ingress	CIR + EIR dropped according to its SVLAN PCP value under congestion conditions
High Priority	CIR policed at ingress EIR = 0	Prioritised

- 3.5.5 The Hyperfibre Service includes the options, exercised by Service Request, to:
  - (a) set the UNI as an untagged interface. If this feature is requested, then the network will remove all 802.1q tags from downstream traffic and present it as 802.3 Ethernet frames from the UNI; and
  - (b) Enable Circuit ID and Remote ID per A-EVPL, as specified in Broadband Forum TR-101/TR-156, per tail. If this feature is requested TR-101 information

will be embedded in DHCP or PPPoE traffic. The Circuit ID format may differ slightly from the examples provided in TR-101/TR-156.

3.6 The core bitstream services provided as part of the Hyperfibre 3 A-EPL Service are as follows:

3.6.1 One Access EPL Service that supports transparent pass-through of 802.1Q frames on a designated UNI on the ONT at the End User Premises.

3.6.2 Delivered over a single 802.1ad SVLAN on the E-NNI at the POI.

3.6.3 Additional bandwidth overhead for Low Priority EIR traffic to compensate for higher protocol encapsulation overheads. This bandwidth overhead does not guarantee End Users will experience the headline speed as their experience is dependent on a number of external factors including, but not limited to, End User applications and local network, the Service Provider network and location of the content they are accessing.

3.6.4 Tagged Traffic is treated as follows:

- (a) Untagged traffic sent from the End User is tagged and treated as Low Priority.
- (b) Traffic tagged with PCP = 0 will be treated as Low Priority.
- (c) Traffic tagged with PCP = 1, 2, 3, 4, 5, 6 or 7 will be treated as High Priority.
- (d) Traffic will be treated as follows based on the individual frame's priority:

Low Priority	CIR ≥ 10 Mbps. EIR ≥ 0. EIR + CIR policed at ingress	EIR Queued and Weighted fairly under congestion conditions.
High Priority	CIR ≥ 0. EIR = 0.	Prioritised.

Low Priority traffic can burst up to the Headline Rate

3.7 The following Initial Service Templates are available:

## Hyperfibre 2 A-EVPL Service Templates

Service templates for Hyperfibre 2 Service:

Templates	Headline <sup>[1]</sup>		Low Priority <sup>[2]</sup> PIR (Mbps)		Low Priority Downstream				Low Priority Upstream				High Priority Downstream				High Priority Upstream			
	Low Priority (Mbps) DS/US	High Priority (Mbps) DS/US			EIR <sup>[3]</sup>	EBS	CIR	CBS	EIR <sup>[3]</sup>	EBS	CIR	CBS	EIR	EBS	CIR	CBS	EIR	EBS	CIR	CBS
			Down	Up	Mbps	kB	Mbps	kB	Mbps	kB	Mbps	kB	Mbps	kB	Mbps	kB	Mbps	kB	Mbps	kB
2G/2G 10/10	2000/2000	10/10	2200	2200	2197.5	10157	2.5	83	2197.5	10157	2.5	83	0	0	10	329	0	0	10	329
4G/4G 10/10	4000/4000	10/10	4400	4400	4397.5	10157	2.5	83	4397.5	10157	2.5	83	0	0	10	329	0	0	10	329
8G/8G 10/10 <sup>[4]</sup>	8000/8000	10/10	8400	8400	8397.5	10157	2.5	83	8397.5	10157	2.5	83	0	0	10	329	0	0	10	329

[1] The headline rate is the Layer 2 bandwidth prior to the addition of the overhead.

[2] Low Priority 'Peak Information Rate' (PIR) is the headline rate plus the bandwidth overhead described in section 3.5.2 plus the Low Priority CIR  
 Low Priority PIR = Low Priority EIR + Low Priority CIR.

[3] These values are the layer 2 bandwidths and include the additional overhead compensation described in section 3.5.2.

[4] As of June 2025 there is a temporary stop-sell in place for Hyperfibre 8G variants.

## Hyperfibre 3 A-EPL Service Templates

Service templates for Hyperfibre 3 Service:

Templates	Headline <sup>[1]</sup>		Low Priority <sup>[2]</sup> PIR (Mbps)		Low Priority Downstream				Low Priority Upstream				High Priority Downstream				High Priority Upstream			
	Low Priority (Mbps) DS/US	High Priority (Mbps) DS/US			EIR <sup>[3]</sup>	EBS	CIR	CBS	EIR <sup>[3]</sup>	EBS	CIR	CBS	EIR	EBS	CIR	CBS	EIR	EBS	CIR	CBS
			Down	Up	Mbps	kB	Mbps	kB	Mbps	kB	Mbps	kB	Mbps	kB	Mbps	kB	Mbps	kB	Mbps	kB
2G/2G 100/100	2000/2000	100/100	2200	2200	2190	9911	10	329	2190	9911	10	329	0	0	100	3278	0	0	100	3278
4G/4G 100/100	4000/4000	100/100	4400	4400	4390	9911	10	329	4390	9911	10	329	0	0	100	3278	0	0	100	3278
8G/8G <sup>[4]</sup> 100/100	8000/8000	100/100	8400	8400	8390	9911	10	329	8390	9911	10	329	0	0	100	3278	0	0	100	3278

[1] The headline rate is the Layer 2 bandwidth prior to the addition of the overhead described in section 3.6.3

[2] Low Priority 'Peak Information Rate', which is the headline rate plus the bandwidth overhead described in clause 3.6.3, is the sum Low Priority EIR and Low Priority CIR.

[3] These values are the layer 2 bandwidths and include the additional overhead compensation described in section 3.6.3.

[4] As of June 2025 there is a temporary stop-sell in place for Hyperfibre 8G variants.

3.7.1 The Hyperfibre Service has similar characteristics to the other services within the UFB family of Bitstream Services as identified below:

Attribute	Bitstream 2a	Hyperfibre 2 Services	Bitstream 3	Hyperfibre 3 Services	Bitstream 3a/3b	Bitstream 4
Bitstream	A-EVPL	A-EVPL	A-EPL	A-EPL	A-EPL	A-EPL
High Priority	Yes	Yes	Yes	Yes	Yes	Yes
Low Priority	Yes	Yes	No	No	Yes	No
MTU	2000 Bytes	2000 Bytes	2000 Bytes	2000 Bytes	2000 Bytes	9100
MAC addresses	16	16	64	64	64	128
Number of available UNIs	4 standard	1 x 10Gbps UNI 1 x 1Gbps UNI	4 standard	1 x 10Gbps UNI 1 x 1Gbps UNI	4 standard	1 with a second UNI available on request
L2CP support	No	No	No	No	No	Limited
Diversity	On request with limited availability	On request with limited availability	On request with limited availability	On request with limited availability	On request with limited availability	Available to Priority Users in selected areas

\* Bandwidth options for each Bitstream Service are detailed in each Bitstream Service Description and further options can be developed using the Product Development Process.

### UNI - NNI characteristics

- 3.7.2 All Hyperfibre Services on a UNI must belong to the same Service Provider and must connect to an E-NNI belonging to that Service Provider. However, each Hyperfibre Service can connect to a different E-NNI at the same or different geographic location within a Coverage Area.
- 3.7.3 Hyperfibre 3 A-EPL requires a dedicated 10Gbps UNI. The additional 1Gbps UNI can be used for additional instances of the Bitstream 2a, 3, 3a, 3b service.
- 3.7.4 The sum of High and Low Priority traffic profiles of all services delivered at a UFB Handover Connection Service can exceed the UFB Handover Connection Service line rate. If there is insufficient line rate to deliver the traffic then frames will be randomly discarded, based on their Class of Service precedence, and Service Levels for that Class of Service do not apply. It is therefore the Service Provider's responsibility to shape and queue traffic appropriately.

### Operations, Administration and Maintenance

- 3.8 The Hyperfibre Service will support Ethernet Service Operations and Maintenance (**OAM**) for service integrity testing, fault diagnostics and performance measurement using ITU Y.1731. OAM capability will be phased in as the functionality is developed and deployed in scale and may be updated or amended by the LFC from time to time.

### Service Requirements

- 3.9 To use the Hyperfibre Service the Service Provider must have the capability to access and interconnect with it, by one of the following:
- 3.9.1 Co-locating Service Provider equipment at the POI using the UFB Handover Connection Service and Central Office and POI Co-location Service;
  - 3.9.2 Connecting to third party co-location space at the POI using the UFB Handover Connection Service, and with the third party taking the Central Office and POI Co-location Service;
  - 3.9.3 Connecting to a backhaul service at the POI;
  - 3.9.4 By using the Direct Fibre Access Service to connect to Service Provider equipment at a remote location within the Central Office area; or
  - 3.9.5 Co-locating Service Provider equipment at the POI using the UFB Handover Connection Service and a third party co-location service.

### **Additional Service Characteristics**

- 3.10 The technical specification of the Hyperfibre Service is set out in Appendix B.
- 3.11 The LFC will provide certain support and other assistance as part of the Hyperfibre Service including:
  - 3.11.1 A tool to assist the Service Provider in determining the location and availability of the Hyperfibre Service (pre-qualification),each as more particularly set out in the Operations Manual.
- 3.12 The Hyperfibre Service specifically excludes:
  - 3.12.1 The UFB Handover Connection Service;
  - 3.12.2 Provision or maintenance of any cabling or connection or active device:
    - (a) beyond the service demarcation points described in clause 4.1 and clause 5.1;
    - (b) between the jack terminating the LFC provided Fibre Lead-in and the ONT, where that cabling or connection is not provided by the LFC and the LFC has not agreed to take responsibility for that cabling or connection;
  - 3.12.3 Configuration, monitoring, operation, on-going support or maintenance of Service Providers' or End Users' applications, equipment or networks; and
  - 3.12.4 Supply of AC mains & UPS power, accommodation space, heating, ventilating, and air conditioning and facilities at the POI or End User Premises.

### **4 Service Demarcation Point at End User Premises**

- 4.1 The service demarcation point at the End User's Premises is the 10000 Base-T (10 Gbps) UNI interface on the XGS-PON ONT.
- 4.2 The Hyperfibre Service excludes the End User Premises wiring. If a fault reported by the Service Provider is found to be caused by the End User Premises equipment (CPE) or the wiring at the End User's Premises beyond the service demarcation point, then the Service Provider may be charged the no fault found fee in the Price List. Note the wiring should comply with the industry standard Premises wiring requirements which are available at [www.tcf.org.nz](http://www.tcf.org.nz).

### **5 Service Demarcation Point at POI**

- 5.1 The Hyperfibre Service is delivered as a transparent VLAN (the logical service demarcation point) on the UFB Handover Connection located at the POI.
- 5.2 The physical service demarcation point is the MOFDF in the POI, which is part of the UFB Handover Connection Service.
- 5.3 The UFB Handover Connection Service is a separate service and is a prerequisite to the supply of the Hyperfibre Service, i.e. Service Providers must first purchase and then continue to maintain a UFB Handover Connection Service at all times while taking the Hyperfibre Service, the UFB Handover Connection Service should ideally be at least two 10Gb ENNI ports in a LAG configuration. XGS-PON will not be supported on 1Gb interfaces and/or on Link Aggregated 1Gb interface(s).

### **6 LFC and Service Provider Responsibilities**

- 6.1 Other LFC and Service Provider responsibilities are detailed in the Trial Agreement, General Terms and the Operations Manual.

## Appendix A - Diagram

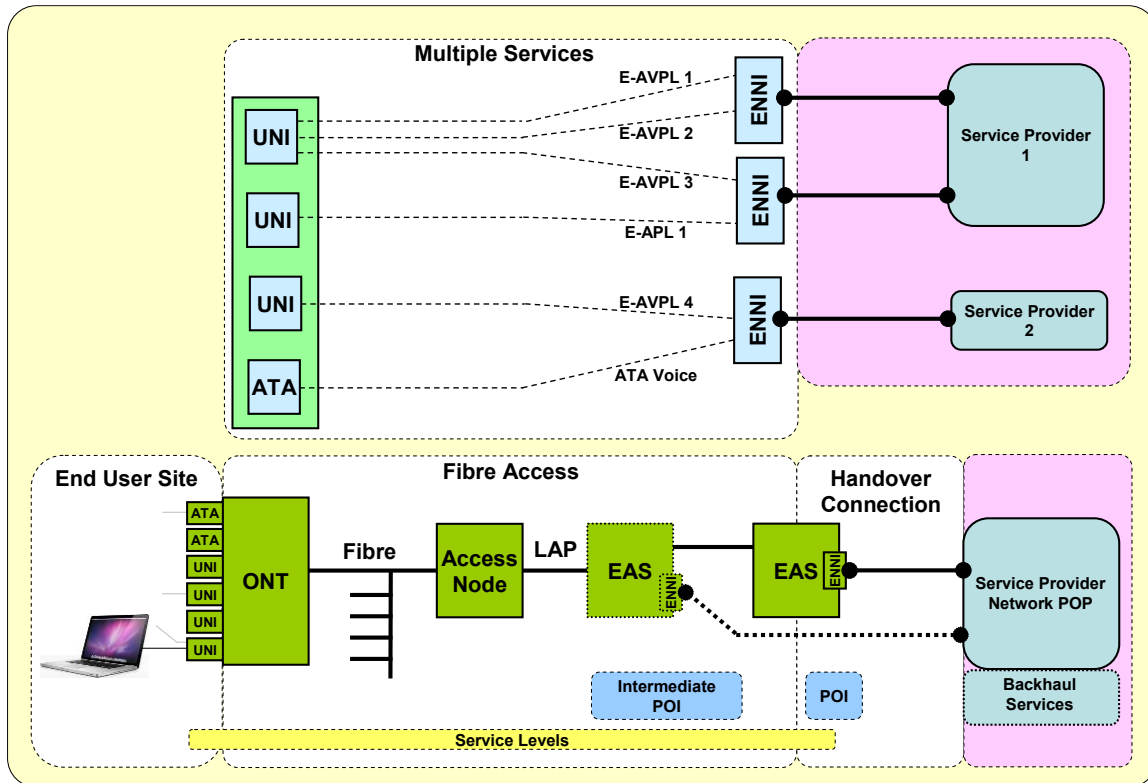

This is a generic diagram showing the standard configuration and service demarcation points. It is not intended to represent every situation or detailed physical architecture. The following points should be noted:

- The Hyperfibre Service and pricing applies from the UNI to the E-NNI at the POI, i.e. there is no incremental charge from the Intermediate POI to the POI.
- Some Bitstream Services will have a single tier of aggregation, i.e. there is no Intermediate POI.
- Where there are multiple tiers of aggregation, the Service Provider can pick the service up at an Intermediate POI. This intermediate POI will service a limited Coverage Area.
- Access node and aggregation interconnection may use redundant links to meet Service Level requirements.

The Bitstream Services support simultaneous delivery of multiple Service Templates from the same or multiple service providers as follows:

- Multiple A-EVPLs can be delivered to the same UNI.
- An A-EPL service requires a dedicated UNI.
- All services delivered to a UNI must belong to the same Service Provider but can be mapped to the same or different E-NNIs.

## Appendix B - Technical Specification

Technical Specification	
Ethernet	<p>Hyperfibre 2 - Ethernet II or 802.3 untagged interface; or 802.1q tagged interface with:</p> <ul style="list-style-type: none"> <li>• VLAN id = as agreed with Service Provider;</li> <li>• 802.1p = 0, 1, 2, 3, 4, 6, 7 (Low Priority); or</li> <li>• 802.1p = 5 (High Priority).</li> </ul> <p>Hyperfibre 3 - IEEE 802.3 – 2005.</p> <ul style="list-style-type: none"> <li>• 802.1q supporting 4050VLANs.</li> </ul>
UNI	<p>XGS-PON ONT Supports:</p> <ul style="list-style-type: none"> <li>• 1x 10G Base-T Ethernet Interface</li> <li>• 1x 1G Base-T Ethernet Interface</li> <li>• 2x ATA Voice Ports</li> </ul>
UFB Handover Connection (E-NNI)	<p>Ethernet:</p> <ul style="list-style-type: none"> <li>• 802.1ad VLAN (SVID, CVID); or</li> <li>• Double tagged QinQ.</li> </ul>
VLAN	<p>Point-to-Point (A-EVPL or A-EPL).            MTU 2000 Bytes.            Unicast Frame Delivery = passed within service CIR/EIR.            Multicast Frame Delivery = passed within service CIR/EIR.            Broadcast Frame Delivery = passed within service CIR/EIR.            Layer 2 Control Protocols Processing = initially none (but may be amended by LFC from time to time).</p>
Fibre	<p>External fibre must comply with ITU-T specification G.652D.            Internal building fibres may comply with ITU-T G.657A but must meet appropriate fire regulations.            Fibre terminations must be SC/APC type connectors (complying with the IEC 61754-4 standard) or alternatively LC/APC type connectors (complying with the IEC 61754-20 standard) as appropriate.            Laser types and path characteristics expected to be designed to a minimum standard which are contained in the documents IEEE 802.3 Section 5 standard OR distance specifications as per the ITU-T G.984 (GPON) standard as appropriate.            Testing for power loss will be at either 1310 or 1550 nm.            1625 nm reserved for non-disruptive testing.</p>