



Enable Networks UFB Services Agreement
Bitstream Services:
Service Description for UFB Handover Connection

1 Interpretation

- 1.1 The UFB Handover Connection Service described in this Service Description will be available from the date it is launched by the LFC. The LFC will notify the Service Provider of the launch date for the UFB Handover Connection Service.
- 1.2 References to clauses or sections are references to clauses or sections in this Service Description unless expressly provided otherwise. The definitions set out in the General Terms and the Operations Manual apply to this Service Description unless expressly provided otherwise.
- 1.3 References to the Operations Manual are references to the Operations Manual for the Bitstream Services.

2 The UFB Handover Connection Service

- 2.1 The UFB Handover Connection Service is a linking service that provides the inter-network connectivity between the other Bitstream Services and the Service Provider networks. The UFB Handover Connection Service is part of the family of Bitstream Services set out below:

Bitstream 2	Based on the TCF Mass Market service.
Bitstream 3	Based on the TCF Business service.
Bitstream 3a	Based on the TCF Business service with Low Priority options.
Bitstream 4	Based on the TCF Business Premium service.
UFB Handover Connection	Based on the TCF E-NNI specification.
Multicast	Based on the TCF Ethernet Multicast Access (EMA) service.
ATA Voice	An analogue telephone access service.

- 2.2 A diagram of the configuration for the UFB Handover Connection Service is set out in Appendix A. The UFB Handover Connection Service provides the Bitstream ENNI functions at the POI that enables a Service Provider to access and interconnect with the LFC Network.
- 2.3 The UFB Handover Connection Service is an input service which a Service Provider can combine with other Bitstream Services (and the Service Provider's own network or wholesale services provided by other providers) to provide fibre based telecommunications services to End Users.
- 2.4 The UFB Handover Connection Service has the following key characteristics:
- 2.4.1 Provides the inter-network connectivity for the following Bitstream Services:
- (a) Bitstream 2;
 - (b) Bitstream 3;
 - (c) Bitstream 3a;
 - (d) Bitstream 4;
 - (e) ATA Voice; and
 - (f) Multicast.
- 2.4.2 Operates as an Ethernet bitstream linking service that allows up to 4050 Service VLANs, each with 4050 End User VLANs, to be passed to the Service Provider.
- 2.4.3 Supports multiple physical links for redundancy and capacity using Link Aggregation Grouping (LAG).

- 2.4.4 Complies with the E-NNI services specified in the Telecommunications Carriers Forum's Ethernet Access Service Description v24, 19 January 2011.

3 UFB Handover Connection Service and implementation activities

Installation Services

- 3.1 The UFB Handover Connection Service includes a Standard Install (in each case to the extent that the relevant provisioning works are not already complete for the relevant Service Order). A Standard Install for the UFB Handover Connection Service includes:
 - 3.1.1 one or more GigE or 10 GigE physical ports at the POI; and
 - 3.1.2 a fibre cable from each physical port to the POI MOFDF.

Core UFB Handover Connection Service

- 3.2 The UFB Handover Connection Service is comprised of:
 - 3.2.1 An Ethernet E-NNI Service that supports the pass-through of other Bitstream Services to an MOFDF at the POI.
 - 3.2.2 Uses double-tagged 802.1ad frames on the E-NNI at the POI. VLAN allocation is based on the Bitstream Services mapped to that E-NNI:
 - (a) Outer tag (Service) VLAN Identifiers (SVID) will be allocated serially commencing with SVID = 2;
 - (b) Inner tag (Customer) VLAN identifiers (CVID) will be allocated or carried according to the Bitstream service; and
 - (c) Bitstream VLAN Identifier allocation rules are as follows:

<u>Bitstream Service</u>	<u>VLAN ID allocation rules</u>
Bitstream 2	SVID, CVID per service instance
Bitstream 3/3a	SVID per service instance. CVID = transparent
Bitstream 4	SVID per service instance. CVID = transparent
ATA Voice ¹	SVID, CVID per service instance
Multicast ²	SVID per service instance

¹ Final VLAN allocation rules for ATA Voice are yet to be defined. There may be a requirement for two VLANs, one for signalling and one for voice.

² As Multicast is delivered through the Product Development Process final VLAN allocation rules will be defined per Service Template.

- 3.2.3 Tagged traffic is treated according to the individual Bitstream Service traffic management rules as set out in the relevant service description.
- 3.2.4 The UFB Handover Connection Service supports two speed options:
 - (a) 1 GigE; and
 - (b) 10 GigE.

This speed represents the maximum bandwidth available to all other Bitstream Services delivered through the UFB Handover Connection Service.
- 3.2.5 LAG allows multiple physical ports to be combined into a single UFB Handover Connection Service. In the event of the failure of one physical link, the traffic management rules apply. Only same speed links may be combined into a LAG group.

Traffic Management Rules

- 3.2.6 On egress (upstream) High Priority traffic is strictly prioritised over Low Priority traffic.
- 3.2.7 The sum of High and Low Priority traffic profiles of all services delivered at a UFB Handover Connection can exceed the UFB Handover Connection line rate. If there is insufficient line rate to deliver the traffic then frames will be randomly discarded, based on their Class of Service precedence, and performance characteristics for that Class of Service do not apply. It is therefore the Service Provider's responsibility to shape and queue traffic appropriately.

Support for multiple Bitstream Services

- 3.3 One instance of the UFB Handover Connection Service can support any combination of other Bitstream Services up to the available VLAN ID allocation space and subject to the maximum bandwidth of the UFB Handover Connection Service selected by the Service Provider under clause 3.2.4.

Operations, Administration and Maintenance

- 3.4 The UFB Handover Connection Service will support Ethernet Service Operations and Maintenance (**OAM**) for service integrity testing, fault diagnostics and performance measurement using ITU Y.1731. OAM capability will be phased in as the functionality is developed and deployed in scale.

Service Requirements

- 3.5 To use the UFB Handover Connection Service the Service Provider must have the capability to access and interconnect with it, by one of the following:
 - 3.5.1 co-locating Service Provider equipment at the POI using the Central Office and POI Co-location Service;
 - 3.5.2 connecting to third party co-location space at the POI with the third party taking the Central Office and POI Co-location Service;
 - 3.5.3 connecting to a backhaul service that connects to the MOFDF at the POI; or
 - 3.5.4 by using a Direct Fibre Access Service to connect to Service Provider equipment at a remote location within the Central Office area.

Additional Service Characteristics

- 3.6 The technical specification of the UFB Handover Connection Service is set out in Appendix B.
- 3.7 The LFC will provide certain support and other assistance as part of the UFB Handover Connection Service including:
 - 3.7.1 an automated facility for service requests; and
 - 3.7.2 an automated facility for fault notifications,each as more particularly set out in the Operations Manual.
- 3.8 The UFB Handover Connection Service specifically excludes:
 - 3.8.1 any other Bitstream Service;
 - 3.8.2 provision or maintenance of any cabling or connection or active device beyond the service demarcation points described in clauses 4.1 and 5.1;
 - 3.8.3 configuration, monitoring, operation, on-going support or maintenance of Service Providers' or End User's applications, equipment or networks; and
 - 3.8.4 supply of AC Mains & UPS Power, accommodation space, heating, ventilating, air conditioning and other similar services and facilities at the POI.

4 End User facing Service Demarcation Point

- 4.1 The End User facing service demarcation point is a nominal point located on the trunk side of the handover EAS. There is no physical demarcation point and no ability to directly connect to this nominal point.

5 Service Demarcation Points at POI

- 5.1 The service demarcation point for the UFB Handover Connection Service at the POI is the MOFDF in the POI.

6 LFC and Service Provider Responsibilities

- 6.1 Other LFC and Service Provider responsibilities are detailed in the General Terms and the Operations Manual.

7 UFB Handover Connection Service Levels

- 7.1 Service Levels for the UFB Handover Connection Service are set out in the Service Level Terms for the Bitstream Services.

8 UFB Handover Connection Diversity

- 8.1 The UFB Handover Connection Service provides a single interface between the other Bitstream Services and the Service Provider's network.
- 8.2 Where a second or subsequent instance of the UFB Handover Connection Service is required to pick up the other Bitstream Services within a Candidate Area, LFC may be able to engineer the second or subsequent UFB Handover Connection Service to provide a level of diversity. There may be practical limitations to providing full physical diversity to some sites. The provision of a separate entry to an LFC Central Office will have unique site specific engineering considerations and will attract additional costs.

Appendix A – Diagram

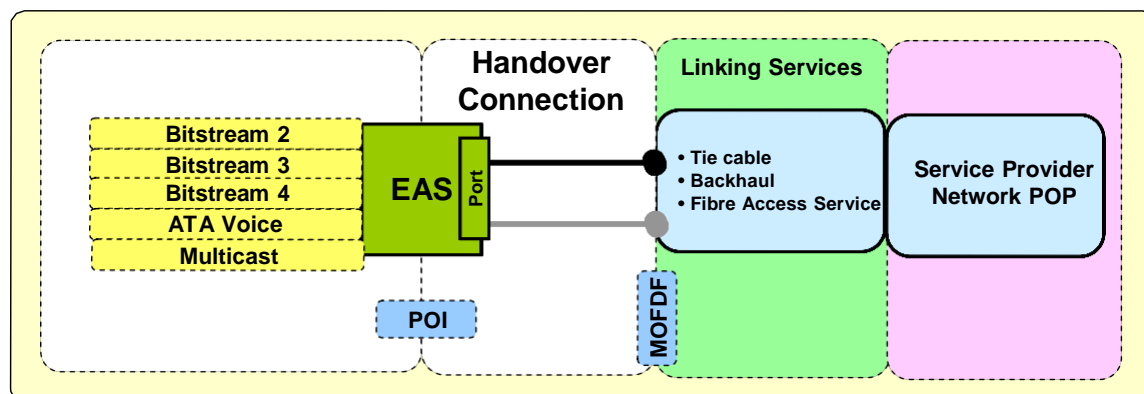

This is a generic diagram showing the standard configuration and service demarcation points. It is not intended to represent every situation or detailed physical architecture. The following point should be noted:

Link Aggregation Grouping (**LAG**) supports N x 1 GigE or N x 10 GigE physical handovers, delivered as a single logical handover.

The UFB Handover Connection Service provides the E-NNI function for the other Bitstream Services. The specific E-NNI attributes are defined in the service descriptions for the other Bitstream Services.

The linking services connect the UFB Handover Connection Service to the Service Provider Network Point of Presence as follows:

- Tie Cables can connect the UFB Handover Connection Service from the MOFDF to Co-location Footprints at the POI. The Footprints can be the Service Provider's Footprint or third party Footprints. Tie Cables to third party Footprints require agreement between the LFC, the Service Provider and the third party.
- Backhaul is a service that can be provided by LFC, the Service Provider or a third party.
- Direct Fibre Access Service can be used to connect to Service Provider equipment at a remote location within the POI Central Office area.

Appendix B – Technical Specification

Technical Specification	
Ethernet	802.1ad VLAN (SVID, CVID); or Double tagged QnQ.
UFB Handover Connection (E-NNI)	E-NNI: 1 GigE: ○ 1310 nm 1000BASE-LX; 10 GigE: ○ 1310 nm 10GBase-LW/LR; 1550 nm 10GBase-EW/ER.
Fibre	External fibre must comply with ITU-T specification G.652D. Internal building fibres may comply with ITU-T G.657A but cable must meet appropriate fire regulations.
Connector Type	Fibre terminations must be SC/APC type connectors (complying with the IEC 61754-4 standard) or LC/APC type connectors (complying with the IEC 61754-20 standard) as appropriate.
Optic Path	Laser types and path characteristics expected to be designed to a minimum standard which are contained in the documents IEEE 802.3 Section 5 standard.